

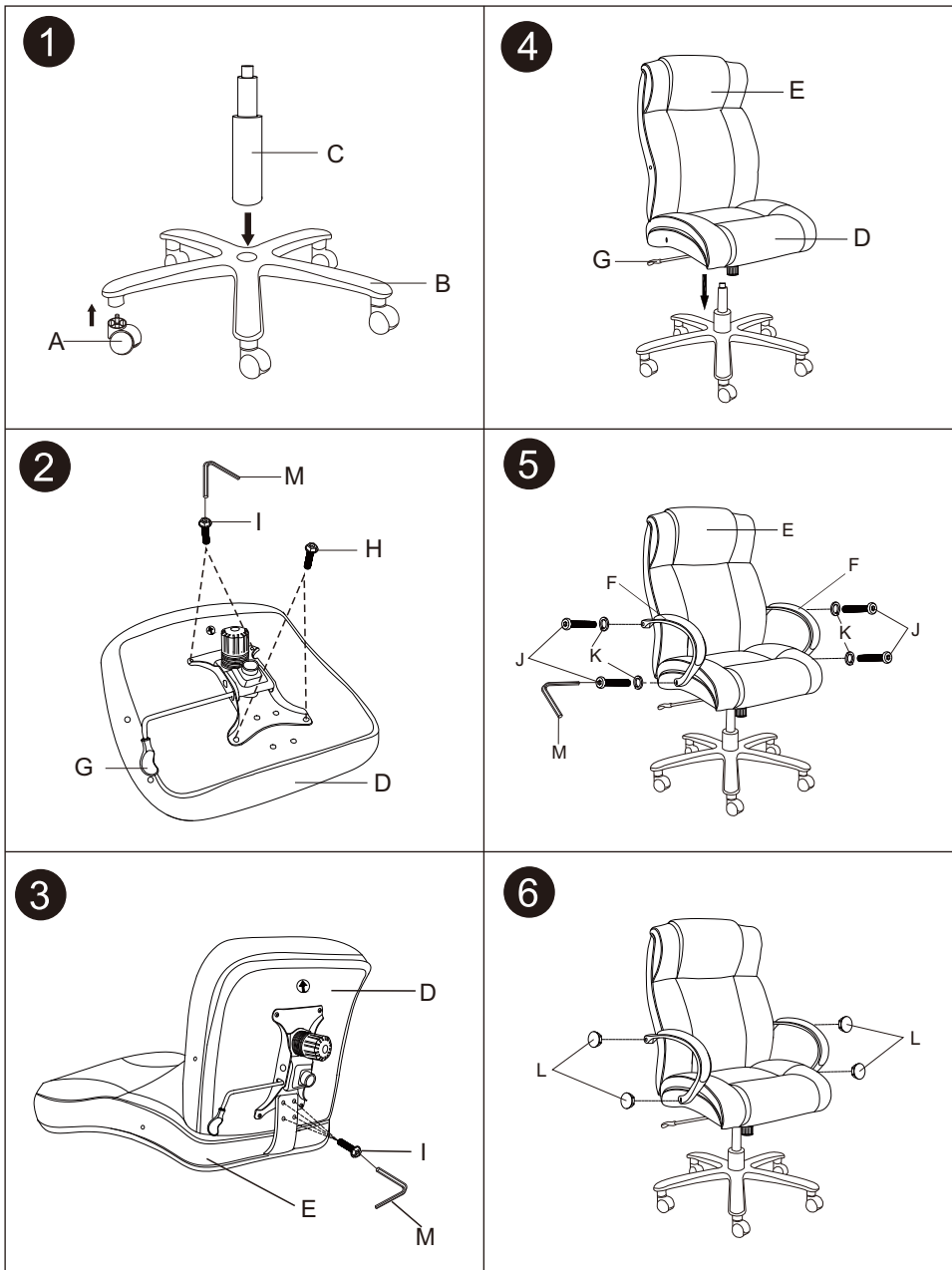

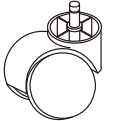

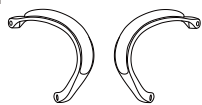

# ASSEMBLY INSTRUCTIONS

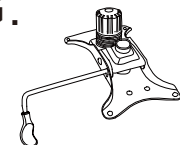

<b>A.</b>  5PCS	<b>F.</b>  2PCS	<b>K.</b>  4PCS
<b>B.</b>  1PC	<b>G.</b>  1PC	<b>L.</b>  4PCS
<b>C.</b>  1PC	<b>H.</b>  2PCS	<b>M.</b>  1PC
<b>D.</b>  1PC	<b>I.</b>  6PCS	
<b>E.</b>  1PC	<b>J.</b>  4PCS	

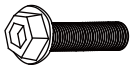
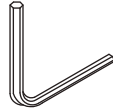
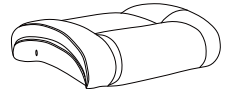
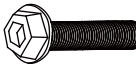
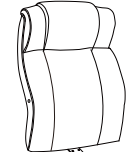
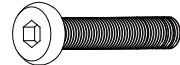
Model: ALE-MS4419

Manufactured for/ Hecho para/ Fabriqué pour Alera® / Essendant Co.

One Parkway North, Deerfield, IL 60015 ©2016 Essendant Co.

Made in/ Hecho en/ Fabriqué en China

Product support and parts: 1-800-733-4000

Ayuda del producto y partes / Support technique et pieces



# OPERATING INSTRUCTIONS

ALE-MS4419

## A. Seat height adjustment

To raise the seat height, stand up from the chair while lifting the lever (A) under the right side of the seat. To lower the seat height, lift the lever (A) while sitting in the chair.

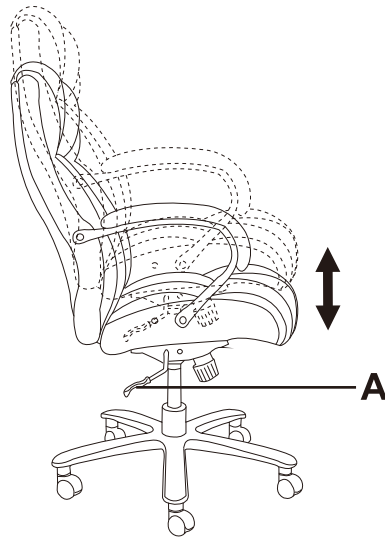

## B. Tilt tension

Knob (B) underneath seat adjusts angle and ease with which chair reclines to the different weights and strengths for different users. To increase tension, turn knob (B) to the right. To release tension (loosen), turn knob (B) to the left.

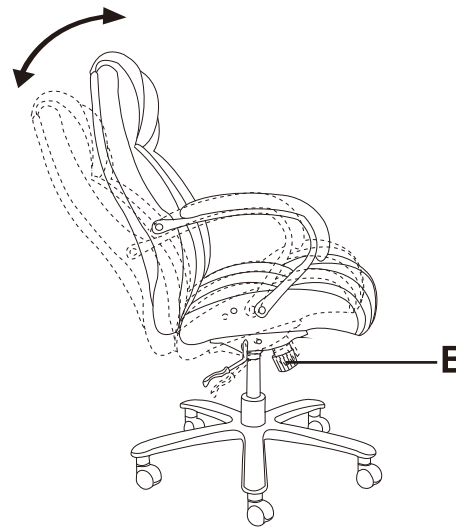

## C. Tilt Lock

Pull lever (A), on the right side of the seat away from the chair and lean back to recline. To lock chair in upright position, push lever back towards the chair.

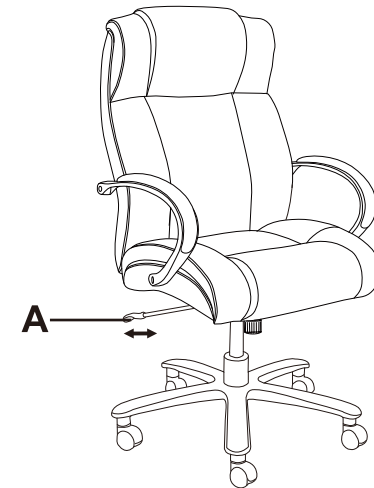



# INSTRUCCIONES DE INSTALACIÓN

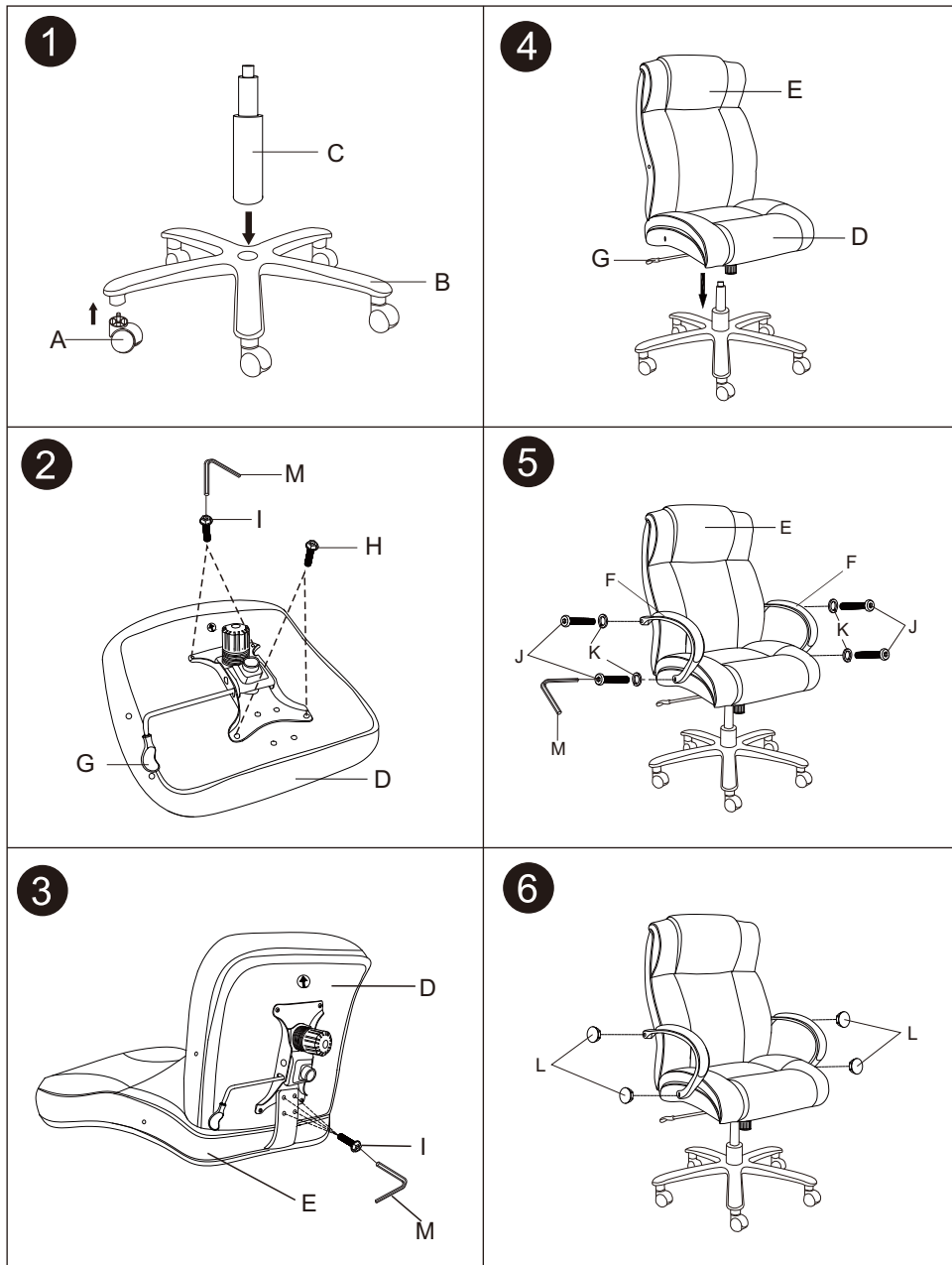

A.  5PZS	F.  2PZS	K.  4PZS
B.  1PZ	G.  1PZ	L.  4PZS
C.  1PZ	H.  2PZS	M.  1PZ
D.  1PZ	I.  6PZS	
E.  1PZ	J.  4PZS	

Modelo: ALE-MS4419

Manufactured for/ Hecho para/ Fabriqué pour Alera® / Essendant Co.

One Parkway North, Deerfield, IL 60015 ©2016 Essendant Co.

Made in/ Hecho en/ Fabriqué en China

Product support and parts: 1-800-733-4000

Ayuda del producto y partes / Support technique et pieces



# INSTRUCCIONRS OPERATIVAS

ALE-MS4419

## A. Ajuste de la altura del asiento

Para subir la altura del asiento, levantarse de la silla mientras se sube el nivel (A) debajo del lado derecho del asiento. Para bajar el asiento, levantar el nivel (A) mientras se está sentado en la silla.

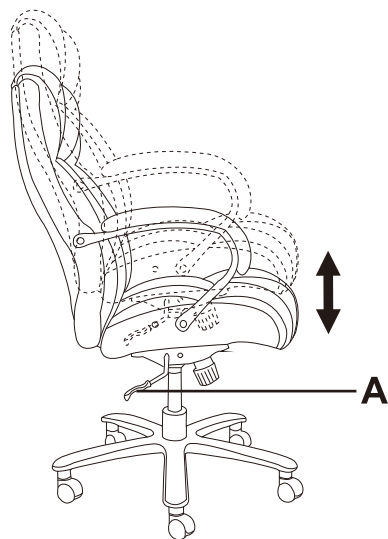

## B. Tensión de inclinación

La palanca (B) debajo de la silla ajusta el ángulo y facilita el movimiento de la silla que se reclina con diferentes pesos y fuerzas para diferentes usuarios. Para aumentar la tensión, girar la palanca (B) hacia la derecha. Para liberar la tensión (soltar) girar la palanca (B) hacia la izquierda.

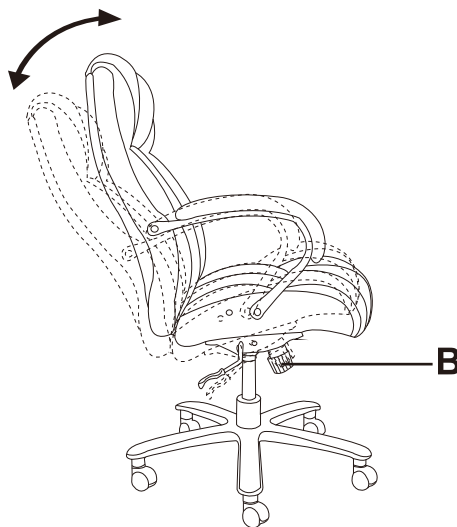

## C. Bloqueo de inclinación

Tira de la palanca (A), hacia en el lado derecho del asiento hacia afuera, recuéstate para reclinarla. Para bloquear la silla en una posición recta, presiona la palanca hacia atrás.

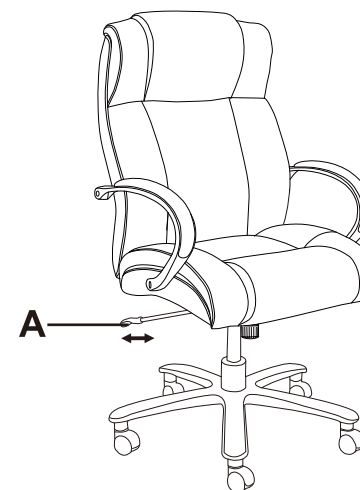



# INSTRUCTIONS DE MONTAGE

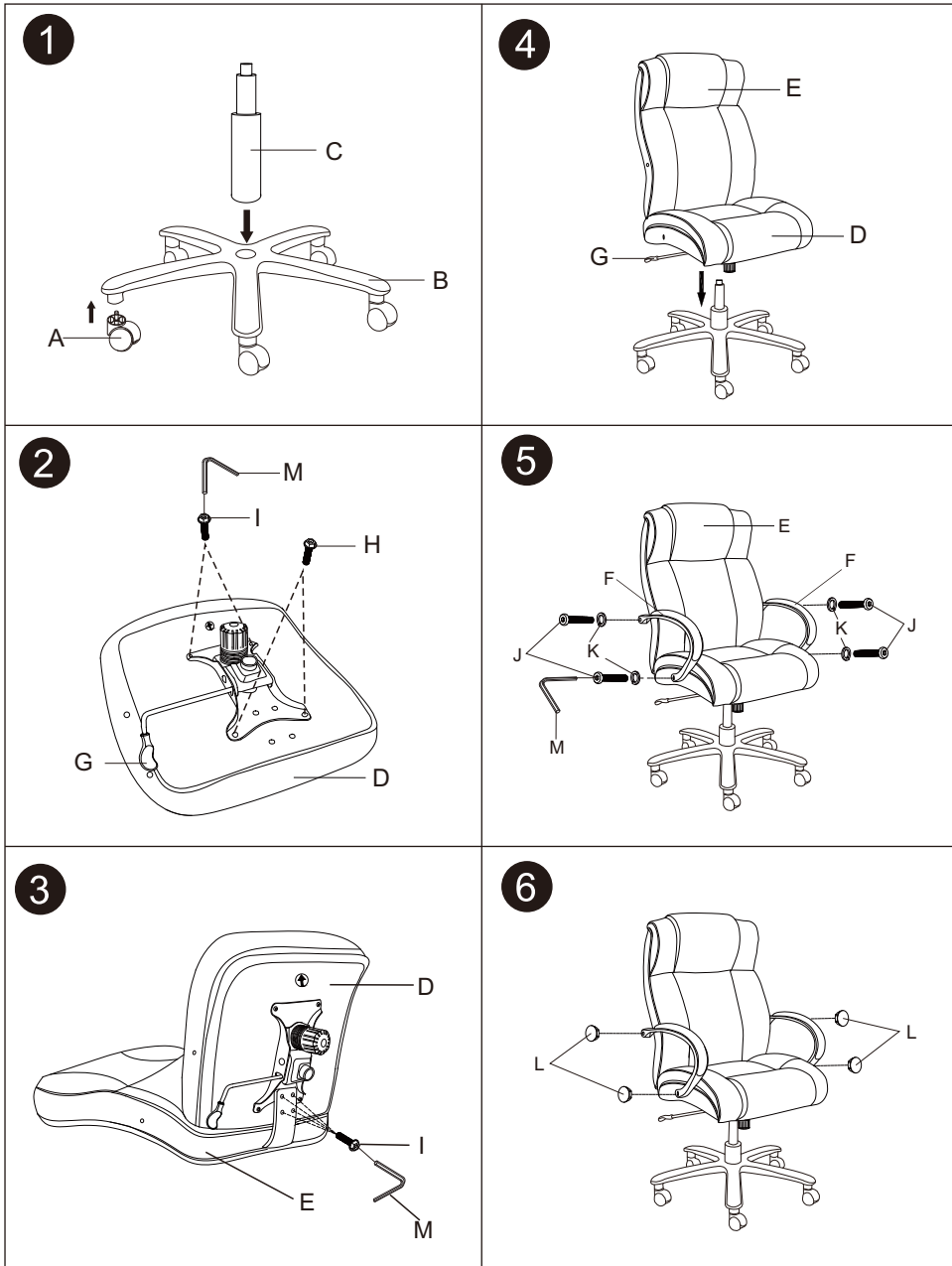

<b>A.</b>  5PIECES	<b>F.</b>  2PIECES	<b>K.</b>  4PIECES
<b>B.</b>  1PIECE	<b>G.</b>  1PIECE	<b>L.</b>  4PIECES
<b>C.</b>  1PIECE	<b>H.</b>  2PIECES	<b>M.</b>  1PIECE
<b>D.</b>  1PIECE	<b>I.</b>  6PIECES	
<b>E.</b>  1PIECE	<b>J.</b>  4PIECES	

Modèle : ALE-MS4419  
 Manufactured for/ Hecho para/ Fabriqué pour Alera® / Essendant Co.  
 One Parkway North, Deerfield, IL 60015 ©2016 Essendant Co.  
 Made in/ Hecho en/ Fabriqué en China  
 Product support and parts: 1-800-733-4000  
 Ayuda del producto y partes / Support technique et pieces



# MODE D'EMPLOI

ALE-MS4419

## A. Réglage de la hauteur du siège

Pour élever la hauteur du siège, se lever de la chaise tout en soulevant le levier (A) sous le côté droit du siège. Pour abaisser la hauteur du siège, soulevez le levier (A) en position assise sur la chaise.

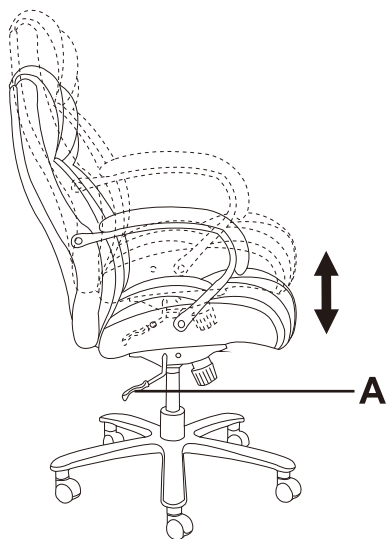

## B. Tension de basculement

Le bouton (B) sous le siège incliné ajuste et facilite quelle chaise incline les différents poids et points forts pour les différents utilisateurs. Pour augmenter la tension, tournez le bouton (B) vers la droite. Pour relâcher la tension (dévisser), tourner le bouton (B) vers la gauche.

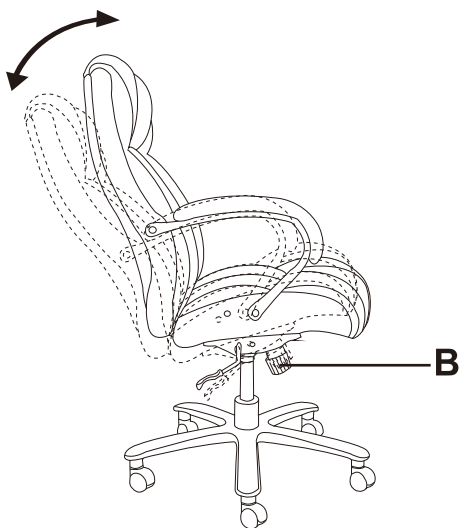

## C. Verrouillage de la bascule

Tirez le levier (A), sur le côté droit du siège loin de la chaise et penchez-vous en arrière pour incliner. Pour verrouiller la chaise, en position verticale, poussez le levier vers la chaise.

